

MaxBit™ Modular Plugs

Modular Plugs made for customers who think the best isn't good enough!SM



- Manufactured to meet or exceed UL 94V-2 fire rated standards**
- Manufactured to meet or exceed UL 1863 standards**
- Blades made with Phosphor Bronze from Germany**
- Blades underplated with 100 microns of Nickel**
- Blades overplated with 50 microns of 99% pure 24 carat GOLD**
- Maximum number of connects and disconnects**
- Bodies are made with crystal clear polycarbonate**
- Most MaxBit modular plugs have the new fantastic 3-prong blades**
- Packaged in zip lock bags**
- Available in RJ-22, RJ-11, RJ-12, RJ-45, and RJ-48 configurations**
- RJ-45 modular plugs available in Cat 5e, Cat 6, and shielded configurations**

Most people think that Modular Plugs are Modular Plugs. Nothing could be farther from the truth. If you have been a computer dealer very long, you have lived thru problems that were extremely difficult to resolve. Only to discover that the flakey problem turned out to be a cable, that initially appeared to be OK. Poor quality Modular Plugs can be attributed to many flakey problems.

MaxBit Modular Plug - Blades

3-Prong Blades are the BEST Modular Plug Contract Blades you can buy. 3-prongs hold the wire in the modular plug better than 2-prong blades. Furthermore, 2-prong blades are more likely to back-out of the modular plug than 3-prong blades. 3-prong blades may be used with either stranded, solid, or modular wire. 2-prong blades have different blades for solid, stranded, and modular. 2-prong blades for solid wire modular plugs have chiseled sides to the blades, where stranded wire modular plugs do NOT have chiseled blades. Generally, you will only find the 3-prong blades on high-quality modular plugs.



MaxBit Modular Plug - Blade Plating

Blades are made of either Phosphor Bronze or Bronze. You should insist upon Phosphor Bronze. Most modular plug contact blades have 24 carat gold plating. The best modular plug contract blades have 100 microns of Nickel underplating over the Phosphor Bronze, followed by 50 microns of 99% pure 24 carat gold overplating. Some sleazy companies use poor grade of nickel plating or NO nickel plating at all. Some sleazy companies will use cheaper grades of gold. 99% pure 24 carat gold is the most expensive. Good plating will double the cost of the modular plugs. But, when you consider that our modular plugs cost approximately 10 cents each, the 5 cents it cost to ensure that you don't have flakey problems later on is well worth the money. Flakey contact problems are some of the most difficult problems to debug. The cost difference between the best modular plug and the worse modular plug are several pennies. Cheap modular plugs are not worth the thousands of dollars of un-necessary service work, a frustrated customer, and your reputation. Remember the phrase, "Penny wise, dollar foolish". All MaxBit modular plugs are underplated with 100 microns of pure Nickel, and overplated with 99% pure 24 carat GOLD.

MaxBit Modular Plug - Amount of Plating

The amount of gold plating will be determined by how many times you can connect and disconnect the modular plugs before all the gold plating wears off. Once the gold plating wears off, the connection will have problems transmitting the signal correctly. A common sleazy tactic by some suppliers is to not mention the amount of gold plating, or to lie about the amount of gold plating. When they do NOT display the amount of gold plating, then the amount of gold plating is usually 3 microns or less (sometimes called 'Flash'). The MAXIMUM amount of gold plating is 50 microns. There are some sleazy suppliers who state that they have more than 50 microns of gold plating. This is a lie. Always insist upon 24 carat gold that is 99% pure. We ONLY sell 50 micron modular plugs with 99% pure 24 carat gold. The price difference between flash and 50 microns is minimal. The pennies you save today, may cost you thousands of dollars tomorrow with flakey problems.

You should never assume that the customer will never plug and unplug the modular plug multiple times. The average modular plug gets plugged and unplugged 250 times during the life of the modular plug. That is why 50 microns of gold should be the ONLY standard that you will accept.

Listed below is a chart of gold plating:

Plating	Number of connects and disconnects
Flash	5 connects
3 microns	35 connects
6 microns	65 connects
15 microns	165 connects
30 microns	325 connects
50 microns	550 connects

MaxBit Modular Plug - Types of Plugs

BODIES: There are two lengths of bodies for modular plugs. There are short bodies and long bodies. In North America most RJ-11/12 plugs are short bodies. In North America most RJ-45/48 plugs are long bodies. You can get RJ-45 with short bodies, but they are difficult to use, and should be avoided. Make sure that any plug you buy have long latches. Latches are the levers used to release the modular plug from the socket. DEC plugs have offset latches to release the plugs from the sockets. European plugs have latches on the side of the modular plug. Good modular plugs are made of clear polycarbonate.



Short-Body



Long-Body



DEC



European Plugs

BODY SIZES: RJ-11 and RJ-12 bodies are exactly the same size bodies. The only difference is the number of contact blades. RJ-11 uses 4 contact blades, where RJ-12 uses 6 contact blades. So when you see 6p4c, this means that it has availability for 6 conductors, and uses 4 of the 6 contact blade slots. RJ-11 modular plugs could be substituted with RJ-12 modular plugs, but not the other way around. RJ-22 handset modular plugs are a different size body than RJ-11 and RJ-12 modular plugs. RJ-22 handset modular plugs are used for coiled handset telephone cords. RJ-22 handset modular plugs are narrower than RJ-11 and RJ-12 bodies. RJ-45 and RJ-48 bodies are exactly the same size. The only difference is that RJ-45 bodies have 8 contact blades where RJ-48 modular plugs have 10 contact blades.

LATCHES: Always insist upon long latches. Short latches can make it very difficult to remove from the modular plug from the socket. Then you take the risk of the customer getting frustrated and ripping the cable out the socket. Shorter latches are slightly cheaper. On RJ-11 and RJ-12 make sure that the latch extends beyond the body of the modular plug. If you want a shorter latch, you can always cut off part of the latch with a pair of wire cutters.

MaxBit Modular Plug - UL Rating

Some modular plugs are rated by UL, and some are not. To confuse the matter more, there are two UL ratings. The first is UL 94V0. The second is UL 94V2. We only sell UL 94V2 rated modular plugs.

MaxBit Modular Plug - Quality Control

MaxBit Modular Plugs Blades start with German made Phosphor Bronze blades. All plating of Nickel and Gold is made with a computerized process to ensure the best possible results. Plating is tested for cracking, chipping, flaws, and good adhesion. The plating is then tested and inspected for:

Temper: Tested for 500 times auto-insert, and testing for cracks development.

Wear resistance: The specification of wear resistance are specified by the thickness of gold plating.

Adhesion: The plating shall be done with an adhesion test, where no separation is evident. It is tested by suddenly cooling in water after 10 minutes 150C heating, and examing with 10X magnification.

Appearance: The gold plating shall completely cover all surfaces and have a uniform appearance to extent that the nature of the basis metal and good commercial practices. It shall have the color of electrodeposited gold consistent with the type used, and it shall be free of blisters, cracks, and peeled areas, when examined at 4X magnification.

Thickness: The gold and nickel plating shall be tested for minimum specification thickness, with an X-ray fluorescence tester.

Additionally, MaxBit modular plugs are designed, tested, and certified to meet the following testing specifications:

Specification	Description of Specification
CNS-3627	Salt spray test methods for electronic components.
CNS-4047	Standard specification for phosphor bronze wire
CNS-4824	Standard specification for gold plating
JIS-3270	Standard specification for copper-beryllium alloy phosphor bronze and nickel silver rods, bars and wires.
MIL-STD-105D	Sampling procedures tables for inspection attributes.
MIL-STD-202	Test methods for electronic and electrical components parts
MIL-G-45204B	Gold plating, electrodeposited.
QQ-N-290	Federal standard nickel plating
ASTM-B488	Electrodeposited coatings of gold for engineering uses.
ASTM-B159M	Phosphor bronze wire.

Part #	Description of Part	Weight	Volume	Qty/Bag	Bags/Case
10760	MaxBit RJ-22 Modular Plugs - 50u - 2p (Handset)	0.16 Lbs/Bag	6.00 ci/Bag	100	150
10773	MaxBit RJ-11 Modular Plugs - 50u - 3p	0.20 Lbs/Bag	8.00 ci/Bag	100	120
10778	MaxBit RJ-12 Modular Plugs - 50u - 3p	0.20 Lbs/Bag	8.00 ci/Bag	100	120
10780	MaxBit RJ-45 Modular Plugs - 50u - 2p (Modular wire)	0.35 Lbs/Bag	11.25 ci/Bag	100	50
10795	MaxBit RJ-45 Modular Plugs - 50u - 3p (Cat 5e)	0.35 Lbs/Bag	11.25 ci/Bag	100	50
10805	MaxBit RJ-45 Modular Plugs - 50u - 3p (Cat 6)	0.35 Lbs/Bag	11.25 ci/Bag	100	50
10806	MaxBit RJ-45 Modular Plugs - 50u - 3p Shielded (Cat 6)	0.54 Lbs/Bag	11.25 ci/Bag	100	50
10815	MaxBit RJ-48 Modular Plugs - 50u - 3p	0.36 Lbs/Bag	11.25 ci/Bag	100	50

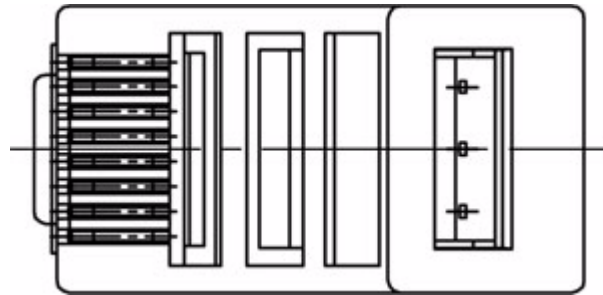
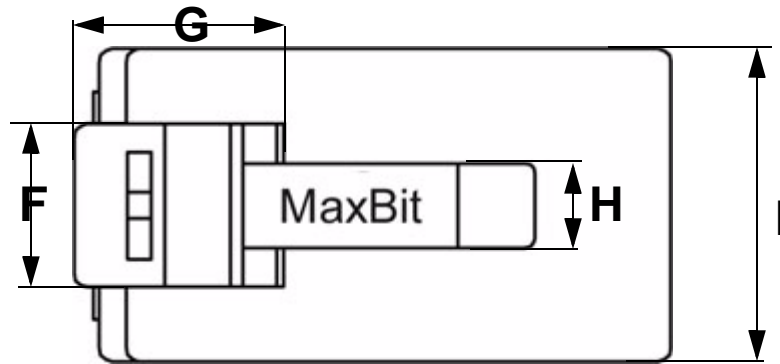
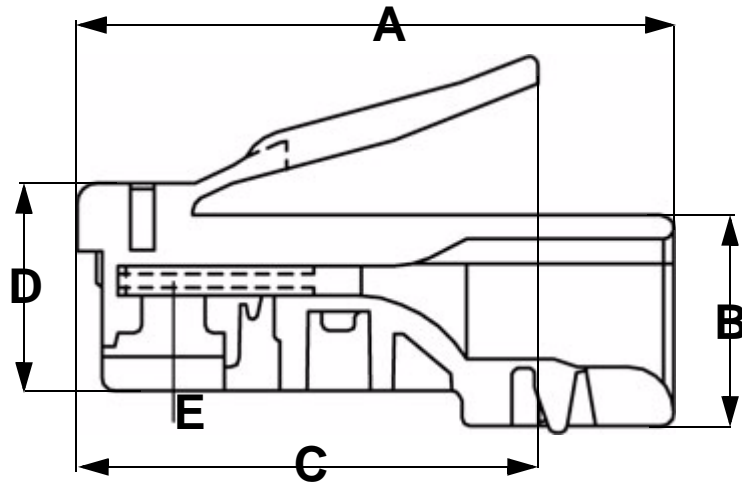

Part #	Type	Prong	A	B	C	D	E	F	G	H	I
10760	RJ-22	2	13.40mm	6.53mm	14.60mm	7.80mm	24 AWG	4.93mm	8.12mm	2.54mm	7.54mm
10773	RJ-11	3	13.40mm	6.53mm	14.60mm	7.80mm	24 AWG	4.93mm	8.12mm	3.17mm	9.60mm
10778	RJ-12	3	13.40mm	6.53mm	14.60mm	7.80mm	24 AWG	4.93mm	8.12mm	3.17mm	9.60mm
10780	RJ-45	2	22.35mm	7.92mm	17.39mm	8.38mm	24 AWG	6.15mm	8.12mm	3.12mm	11.68mm
10795	RJ-45	3	22.35mm	7.92mm	17.39mm	8.38mm	24 AWG	6.15mm	8.12mm	3.12mm	11.68mm
10805	RJ-45	3	22.35mm	7.92mm	17.39mm	8.38mm	23 AWG	6.15mm	8.12mm	3.12mm	11.68mm
10806	RJ-45	3	22.35mm	7.92mm	17.39mm	8.38mm	23 AWG	6.15mm	8.12mm	3.12mm	11.68mm
10815	RJ-48	3	22.35mm	7.92mm	17.39mm	8.38mm	24 AWG	6.15mm	8.12mm	3.12mm	11.68mm

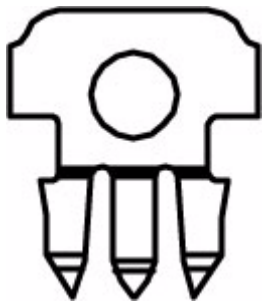
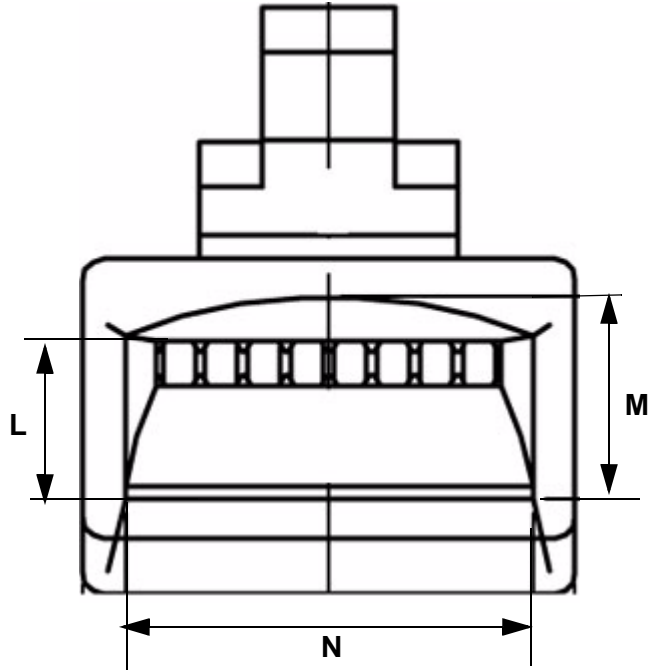
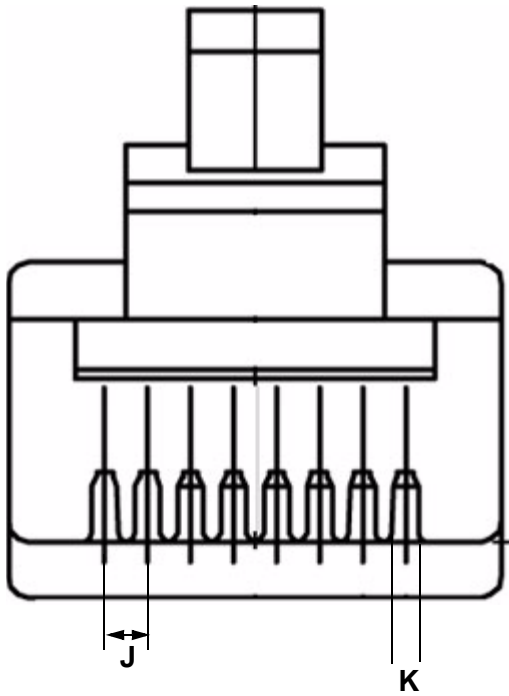

3-Prong Blade

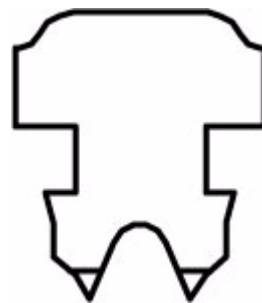

2-Prong Blade

Part #	Type	Prong	J	K	L	M	N
10760	RJ-22	2	1.70mm	1.04mm	2.84mm	2.84mm	5.17mm
10773	RJ-11	3	1.70mm	1.04mm	3.39mm	4.19mm	5.25mm
10778	RJ-12	3	1.70mm	1.04mm	3.39mm	4.19mm	7.23mm
10780	RJ-45	2	1.70mm	1.04mm	3.88mm	3.88mm	9.65mm
10795	RJ-45	3	1.70mm	1.04mm	3.88mm	4.81mm	9.65mm
10805	RJ-45	3	1.70mm	1.04mm	4.73mm	4.73mm	9.65mm
10806	RJ-45	3	1.70mm	1.04mm	4.73mm	4.73mm	9.65mm
10815	RJ-48	3	1.70mm	1.04mm	3.88mm	4.81mm	10.11mm



Catskill Supply Inc
 PO Box 421
 Selkirk NY 12158
www.catskillsupply.com
 (888) 475-5044